



# Lead Screw Nut

THK General Catalog

## A Product Descriptions

<b>Features</b> .....	A16-2
Features of the Lead Screw Nut.....	A16-2
• Structure and Features .....	A16-2
• Features of the Special Rolled Shafts..	A16-3
• High Strength Zinc Alloy.....	A16-3
<b>Point of Selection</b> .....	A16-5
Selecting a Lead Screw Nut.....	A16-5
Efficiency and Thrust.....	A16-8
Accuracy Standards .....	A16-9
<b>Dimensional Drawing, Dimensional Table</b>	
Model DCM.....	A16-10
Model DC.....	A16-12
<b>Point of Design</b> .....	A16-14
Fit.....	A16-14
Installation .....	A16-14
Lubrication .....	A16-16
<b>Model No.</b> .....	A16-17
• Model Number Coding.....	A16-17

## B Support Book (Separate)

<b>Features</b> .....	B16-2
Features of the Lead Screw Nut.....	B16-2
• Structure and Features .....	B16-2
• Features of the Special Rolled Shafts..	B16-3
• High Strength Zinc Alloy.....	B16-3
<b>Point of Selection</b> .....	B16-5
Selecting a Lead Screw Nut.....	B16-5
• Example of selection calculation .....	B16-7
Efficiency and Thrust.....	B16-8
• Example of thrust force calculation .....	B16-8
<b>Mounting Procedure and Maintenance</b> ..	B16-9
Installation .....	B16-9
Lubrication .....	B16-10
<b>Model No.</b> .....	B16-11
• Model Number Coding.....	B16-11

## Features of the Lead Screw Nut

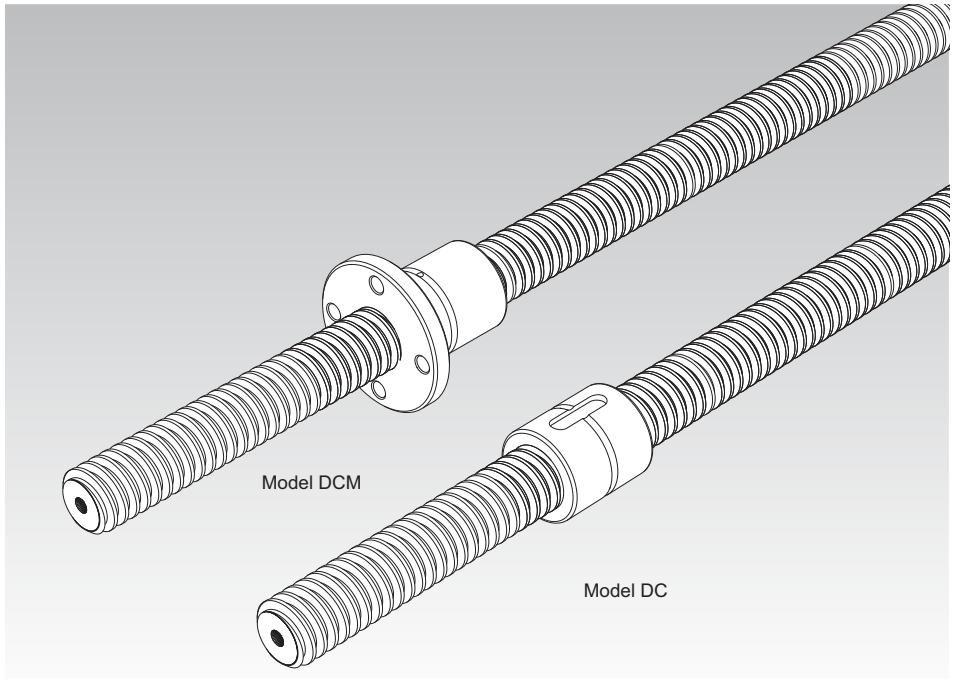

---

### Structure and Features

---

The lead Screw Nut models DCM and DC are manufactured to meet the standards for the 30° trapezoidal threads. They use a special alloy (see **A16-3**) for the nuts and have a precision male thread, formed through die casting, as the core. As a result, these bearings achieve less unevenness in accuracy and higher accuracy and wear resistance than the machined lead screw nuts.

For the screw shafts to be used with this product, the rolled shafts are available as the standard.

In addition, the cut screw shafts and the ground screw shafts are also available according to the application. Contact THK for details.

## Features of the Special Rolled Shafts

The dedicated rolled shafts with the standardized lengths are available for the Lead Screw Nut.

### [Increased Wear Resistance]

The shaft teeth are formed by cold gear rolling, and the surface of the tooth surface is hardened to over 250 HV and are mirror-finished. As a result, the shafts are highly wear resistant and achieve significantly smooth motion when used in combination with lead screw nuts.

### [Improved Mechanical Properties]

Inside the teeth of the rolled shaft, a fiber flow occurs along the contour of the tooth surface of the shaft, making the structure around the teeth roots dense. As a result, the fatigue strength is increased.

### [Additional Machining of the Shaft End Support]

Since each shaft is rolled, additional machining of the support bearing of the shaft end can easily be performed by lathing or milling.

## High Strength Zinc Alloy

The high strength zinc alloy used in the lead screw nuts is a material that is highly resistant to seizure and the wear and has a high load carrying capacity. Its composition, the mechanical properties, the physical properties and the wear resistance are given below.

### [Composition]

Table1 Composition of the High Strength Zinc Alloy

Unit: %

Item	Description
Al	3 to 4
Cu	3 to 4
Mg	0.03 to 0.06
Be	0.02 to 0.06
Ti	0.04 to 0.12
Zn	Remaining portion

**[Mechanical Properties]**

Table2

Item	Description
Tensile strength	275 to 314 N/mm <sup>2</sup>
Tensile yield strength (0.2%)	216 to 245 N/mm <sup>2</sup>
Compressive strength	539 to 686 N/mm <sup>2</sup>
Compressive yield strength (0.2%)	294 to 343 N/mm <sup>2</sup>
Fatigue strength	132 N/mm <sup>2</sup> × 10 <sup>7</sup> (Schenk bending test)
Charpy impact	0.098 to 0.49 N-m/mm <sup>2</sup>
Elongation	1 to 5 %
Hardness	120 to 145 HV

**[Physical Properties]**

Table3

Item	Description
Specific gravity	6.8
Specific heat	460 J/ (kg·K)
Melting point	390 °C
Thermal expansion coefficient	24 × 10 <sup>-6</sup>

**[Wear Resistance]**

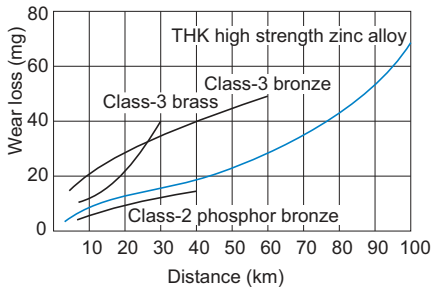

Fig.1 Wear Resistance of the High Strength Zinc Alloy

Table4 [Test conditions: Amsler wear-tester]

Item	Description
Test piece rotational speed	185 min <sup>-1</sup>
Load	392 N
Lubricant	Dynamo oil

## Selecting a Lead Screw Nut

### [Dynamic Permissible Torque T and Dynamic Permissible Thrust F]

The dynamic permissible torque (T) and the dynamic permissible thrust (F) are the torque and the thrust at which the contact surface pressure on the tooth surface of the bearing is 9.8 N/mm<sup>2</sup>. These values are used as a measuring stick for the strength of the lead screw nut.

### [pV Value]

With a sliding bearing, a pV value, which is the product of the contact surface pressure (p) and the sliding speed (V), is used as a measuring stick to judge whether the assumed model can be used. Use the corresponding pV value indicated in Fig.1 as a guide for selecting a lead screw nut. The pV value varies also according to the lubrication conditions.

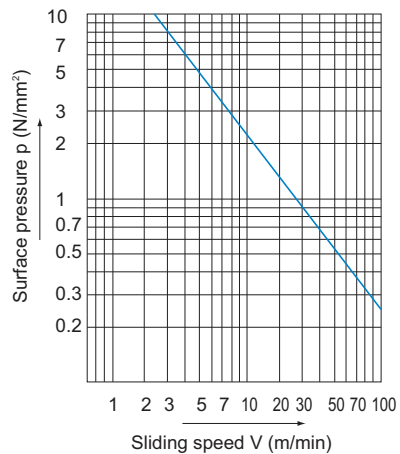

Fig.1 pV Value

### ● fs: Safety Factor

To calculate a load applied to the lead screw nut, it is necessary to accurately obtain the effect of the inertia that changes with the weight and dynamic speed of an object. In general, with the reciprocating or the rotating machines, it is not easy to accurately obtain all the factors such as the effect of the start and stop, which are always repeated. Therefore, if the actual load cannot be obtained, it is necessary to select a bearing while taking into account the empirically obtained safety factors (fs) shown in Table1.

Table1 Safety Factor (fs)

Type of load	Lower limit of fs
For a static load less frequently used	1 to 2
For an ordinary single-directional load	2 to 3
For a load accompanied by vibrations/impact	4 or greater

● **f<sub>r</sub>: Temperature Factor**

If the temperature of the lead screw nut exceeds the normal temperature range, the seizure resistance of the nut and the strength of the material will decrease. Therefore, it is necessary to multiply the dynamic permissible torque (T) and the dynamic permissible thrust (F) by the corresponding temperature factor indicated in Fig.2. Accordingly, when selecting a lead screw nut, the following equations need to be met in terms of its strength.

Static permissible thrust(F)

$$f_s \leq \frac{f_r \cdot F}{P_F}$$

- f<sub>s</sub> : Safety factor (see Table1 on **A16-5**)
- f<sub>r</sub> : Temperature factor (see Fig.2)
- F : Dynamic permissible thrust (N)
- P<sub>F</sub> : Axial load (N)

● **Hardness of the Surface and the Wear Resistance**

The hardness of the shaft significantly affects the wear resistance of the lead screw nut. If the hardness is equal to or less than 250 HV, the abrasion loss increases as indicated in Fig.3. The roughness of the surface should preferably be 0.80a or less.

A special rolled shaft achieves the surface hardness of 250 HV or greater, through hardening as a result of rolling, and surface roughness of 0.20a or less. Therefore, the dedicated rolled shaft is highly wear resistant.

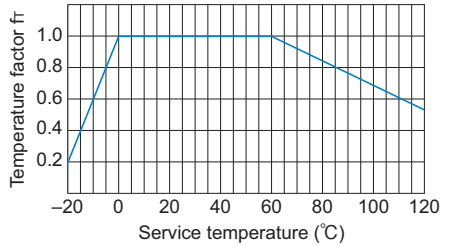

Fig.2 Temperature Factor

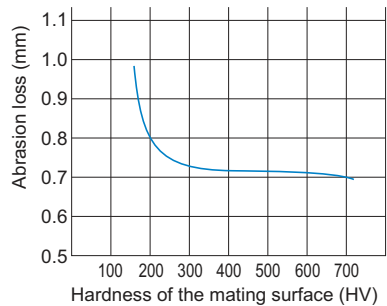

Fig.3 Hardness of the Surface and Wear Resistance

**[Calculating the Contact Surface Pressure p]**

The value of “p” is obtained as followed.

$$p = \frac{P_F}{F} \times 9.8$$

p : Contact surface pressure on the tooth from an axial load ( $P_F$  N) (N/mm<sup>2</sup>)

F : Dynamic permissible thrust (N)

$P_F$  : Axial load (N)

**[Calculating the Sliding Speed V on the Teeth]**

The value of “V” is obtained as followed.

$$V = \frac{\pi \cdot D_o \cdot n}{\cos \alpha \times 10^3}$$

V : Sliding speed (m/min)

$D_o$  : Effective diameter (see specification table) (mm)

n : Revolutions per minute (min<sup>-1</sup>)

$$n = \frac{S}{R \times 10^{-3}}$$

S : Feeding speed (m/min)

R : Lead (mm)

$\alpha$  : Lead angle (see specification table) (°)

# Efficiency and Thrust

The efficiency ( $\eta$ ) at which the screw transfers a torque into thrust is obtained from the following equation.

$$\eta = \frac{1 - \mu \tan \alpha}{1 + \mu / \tan \alpha}$$

- $\eta$  : Efficiency
- $\alpha$  : Lead angle
- $\mu$  : Frictional resistance

Fig.4 shows the result of the above equation.

The thrust generated when a torque is applied is obtained from the following equation.

$$F_a = \frac{2 \cdot \pi \cdot \eta \cdot T}{R \times 10^{-3}}$$

- $F_a$  : Thrust generated (N)
- $T$  : Torque (input) (N-m)
- $R$  : Lead (mm)

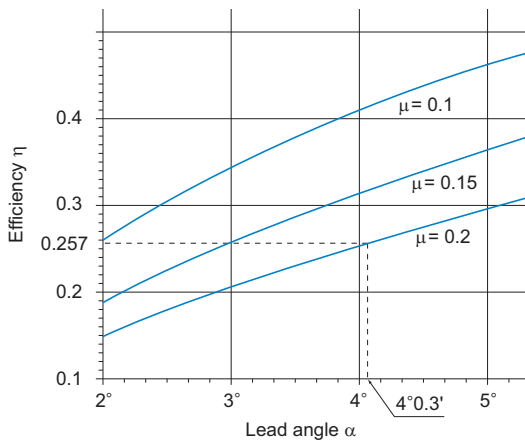

Fig.4 Efficiency

# Accuracy Standards

Table2 Accuracy of the Screw Shaft of Models DCM and DC

Unit: mm

Shaft symbol	Rolled shaft	Cut shaft	Ground shaft
Accuracy	T <sup>Note</sup>	K <sup>Note</sup>	G <sup>Note</sup>
Single pitch error (max)	±0.020	±0.015	±0.005
Accumulated pitch error (max)	±0.15/300	±0.05/300	±0.015/300

Note) Symbols T, K and G indicate machining methods for the screw shaft. The cut shafts and ground shafts are build-to-order. For maximum shaft lengths of cut shafts or ground shafts, contact THK.

# Model DCM

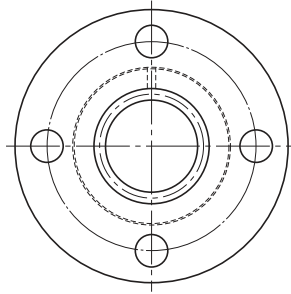

Lead Screw Nut Model No.	Outer dimensions			Lead screw nut dimensions						
	Outer diameter		Length L	Flange diameter D <sub>1</sub>	H	B	PCD	r	F	d
	D	Tolerance h9								
DCM 12	22	0 -0.052	30	44	6	5.4	31	1.5	7	1.5
DCM 14	22		30	44	6	5.4	31	1.5	7	1.5
DCM 16	28		35	51	7	6.6	38	1.5	8	1.5
DCM 18	32	0 -0.062	40	56	7	6.6	42	1.5	10.5	2
DCM 20	32		40	56	7	6.6	42	1.5	10.5	2
DCM 22	36		50	61	8	6.6	47	2	14	2.5
DCM 25	36		50	61	8	6.6	47	2	14	2.5
DCM 28	44		56	76	10	9	58	2	15	2.5
DCM 32	44		56	76	10	9	58	2	15	2.5
DCM 36	52	0 -0.074	60	84	10	9	66	2.5	17	3
DCM 40	58		70	98	12	11	76	2.5	19	3
DCM 45	64		75	104	12	11	80	2.5	21.5	4
DCM 50	68		80	109	12	11	85	2.5	24	4

Note1) Cut shafts (K) and ground shafts (G) are build-to-order. In the specification table, "standard shaft length" and "maximum shaft length" are values for rolled shafts (T).

For maximum shaft lengths of cut shafts (K) or ground shafts (G), contact THK.

Note2) The dynamic permissible thrust (F) indicates the torque at which the contact surface pressure on the screw tooth surface is 9.8 N/mm<sup>2</sup>.

Note3) The static permissible load (P) of the flange indicates the strength of the flange against the load as shown in the figure on the right.

## Model number coding

Combination of lead screw nut and screw shaft

**2 DCM20 +1500L T**

Model number of lead screw nut
Overall screw shaft length (in mm)
How the screw shaft is processed (T: rolled shaft)

Number of lead screw nuts used on the same shaft

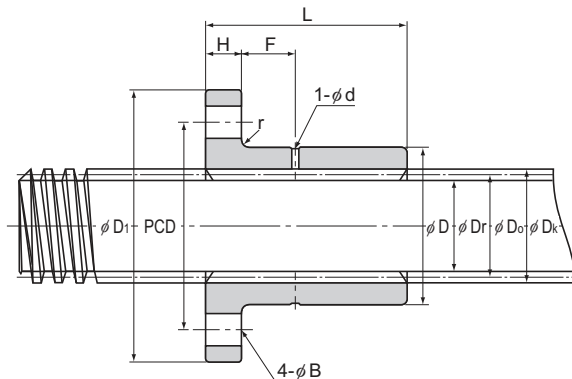

Unit: mm

Screw shaft Model No. <small>(note)</small>	Screw shaft details						Standard shaft length	Maximum shaft length	Dynamic permissible thrust $F$ <small>(note 2)</small>	Static permissible load of the flange $P$ <small>(note 3)</small>	Mass	
	Outer diameter	Effective diameter	Thread minor diameter	Lead	Lead angle	Screw nut					Screw shaft	
	$D_k$	$D_0$	$D_r$	$R$	$\alpha$	g					kg/m	
CS 12	12	11	9.5	2	3°19'	1000	1500	3920	20200	100	0.8	
CS 14	14	12.5	10.5	3	4°22'	1000	1500	4900	16900	85	1	
CS 16	16	14.5	12.5	3	3°46'	1000	1500	6670	31500	160	1.3	
CS 18	18	16	13.5	4	4°33'	1000	2000	8730	42000	230	1.6	
CS 20	20	18	15.5	4	4°03'	1500	2000	9800	37200	210	2	
CS 22	22	19.5	16.5	5	4°40'	1500	2500	12400	48600	320	2.3	
CS 25	25	22.5	19.5	5	4°03'	1500	3000	14200	39800	290	3.1	
CS 28	28	25.5	22.5	5	3°34'	2000	3000	17900	69200	550	4	
CS 32	32	29	25.5	6	3°46'	2000	4000	21100	54200	490	5.2	
CS 36	36	33	29.5	6	3°19'	2000	4000	25800	84500	670	6.7	
CS 40	40	37	33.5	6	2°57'	2000	4000	33800	106000	980	8.4	
CS 45	45	41	36.5	8	3°33'	3000	5000	42100	125000	1310	10.4	
CS 50	50	46	41.5	8	3°10'	3000	5000	50100	128000	1430	13	

Lead Screw Nut

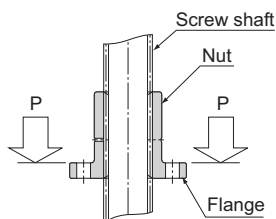

### Model number coding

- Lead screw nut only

**DCM20**

Model number of lead screw nut

- Screw shaft

**CS20 T +1500L**

Model number of screw shaft is processed (T: rolled shaft) Overall screw shaft length (in mm)

# Model DC

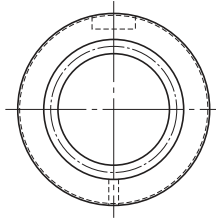

Lead Screw Nut  Model No.	Outer dimensions			Lead screw nut dimensions					
	Outer diameter		L 0 -0.3	Keyway dimensions				d	r
	D	Tolerance h9		b	Tolerance N9	t	ℓ		
DC 12	22	-0.052	22	4	-0.030	2	16	1.5	1
DC 14	22		22	4		2	16	1.5	1
DC 16	28		26	5		2.5	18	1.5	1
DC 18	32	-0.062	31	7	-0.036	2.5	22	2	1
DC 20	32		31	7		2.5	22	2	1
DC 22	36		40	7		2.5	26	2.5	1
DC 25	36		40	7		2.5	26	2.5	1
DC 28	44		45	10		4	32	2.5	1.5
DC 32	44		45	10		4	32	2.5	1.5
DC 36	52	-0.074	49	12	-0.043	4.5	40	3	1.5
DC 40	58		57	15		5	42	3	1.5
DC 45	64		62	15		5	48	4	1.5
DC 50	68		67	15		5	52	4	1.5

Note1) Cut shafts (K) and ground shafts (G) are build-to-order. In the specification table, "standard shaft length" and "maximum shaft length" are values for rolled shafts (T).

For maximum shaft lengths of cut shafts (K) or ground shafts (G), contact THK.

Note2) The dynamic permissible thrust (F) indicates the torque at which the contact surface pressure on the screw tooth surface is 9.8 N/mm<sup>2</sup>.

## Model number coding

Combination of lead screw nut and screw shaft

**2 DC20 +1500L T**

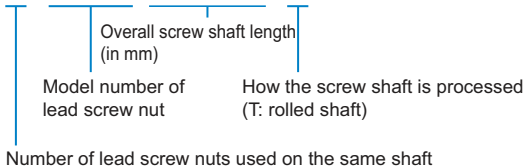

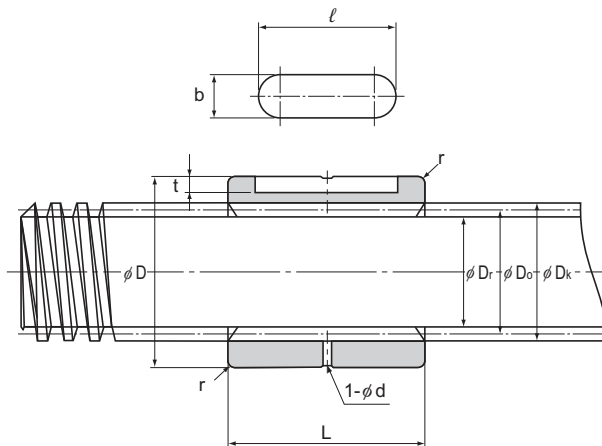

Unit: mm

Screw shaft	Screw shaft details					Standard shaft length	Maximum shaft length	Dynamic permissible thrust F <sup>(note 2)</sup> N	Mass	
	Model No. <sup>(note)</sup>	Outer diameter D <sub>e</sub>	Effective diameter D <sub>o</sub>	Thread minor diameter D <sub>r</sub>	Lead R				Lead angle α	Screw nut g
CS 12	12	11	9.5	2	3°19'	1000	1500	2840	40	0.8
CS 14	14	12.5	10.5	3	4°22'	1000	1500	3630	45	1
CS 16	16	14.5	12.5	3	3°46'	1000	1500	4900	75	1.3
CS 18	18	16	13.5	4	4°33'	1000	2000	6860	120	1.6
CS 20	20	18	15.5	4	4°03'	1500	2000	7650	110	2
CS 22	22	19.5	16.5	5	4°40'	1500	2500	9900	180	2.3
CS 25	25	22.5	19.5	5	4°03'	1500	3000	11400	155	3.1
CS 28	28	25.5	22.5	5	3°34'	2000	3000	14400	280	4
CS 32	32	29	25.5	6	3°46'	2000	4000	17100	230	5.2
CS 36	36	33	29.5	6	3°19'	2000	4000	21200	380	6.7
CS 40	40	37	33.5	6	2°57'	2000	4000	27500	520	8.4
CS 45	45	41	36.5	8	3°33'	3000	5000	34900	730	10.4
CS 50	50	46	41.5	8	3°10'	3000	5000	42100	810	13

Lead Screw Nut

### Model number coding

- Lead screw nut only

**DC20**

Model number of lead screw nut

- Screw shaft

**CS20 T +1500L**

Model number of screw shaft | How the screw shaft is processed (T: rolled shaft) | Overall screw shaft length (in mm)

## Fit

For the fitting between the screw nut outer diameter and the housing, we recommend a loose fit.  
Housing inner-diameter tolerance: G7

## Installation

### [About Chamfer of the Housing's Mouth]

To increase the strength of the root of the flange of the lead screw nut, the corner is machined to have an R shape. Therefore, it is necessary to chamfer the inner edge of the housing's mouth.

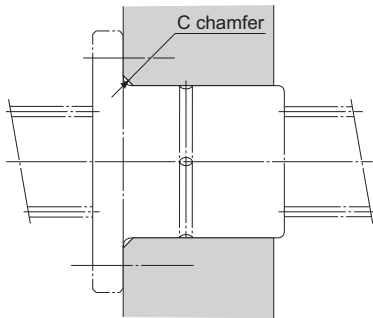

Fig.1

Table1 Chamfer of the Housing's Mouth

Unit: mm

Model No.	Chamfer of the mouth C (Min.)
DCM	
12	2
14	
16	
18	
20	
22	2.5
25	
28	
32	
36	3
40	
45	
50	

**[Recommended Mounting Orientation]**

When vertically conveying a heavy object using the screw shaft, it is safe to mount the screw as shown in Fig.2 where supports are provided on the mounting holes to prevent the moving object from falling even if the lead screw nut is broken due to an overload or an impact.

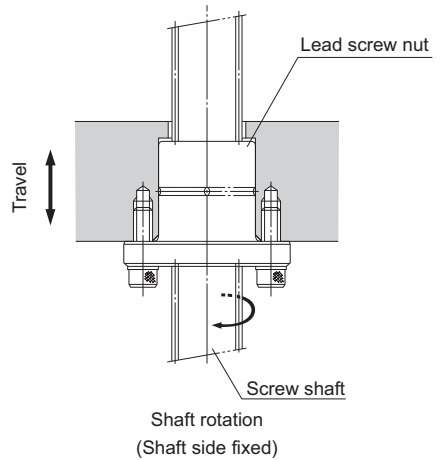

Fig.2 Recommended Mounting Orientation

**[Example of Installation]**

Fig.3 shows examples of mounting the lead screw nuts. When mounting a lead screw nut, secure sufficient tightening strength in the axial direction. For the housing inner-diameter tolerance, see the section concerning fitting on **A16-14**.

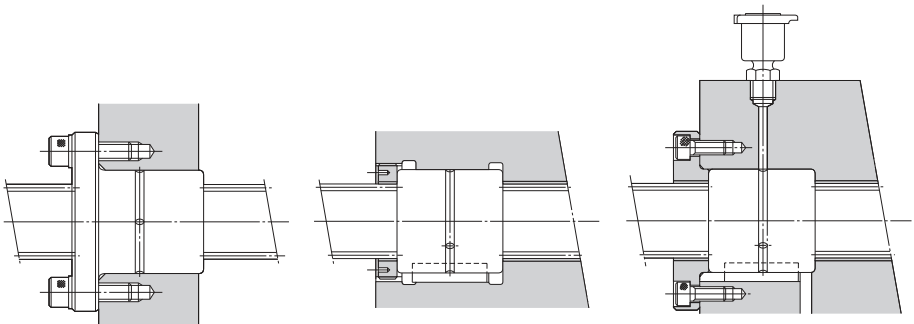

Fig.3 Examples of Installing the Lead Screw Nut

# Lubrication

Since the Screw Nut is delivered without a lubricant/grease, it is necessary to replenish an appropriate amount of lubricant/grease after installing the bearing. Select a lubrication method according to the service conditions.

## [Oil Lubrication]

For lubrication of the lead screw nut, an oil lubrication is recommended. Specifically, an oil-bath lubrication or drop the lubrication is particularly effective. An oil-bath lubrication is the most appropriate method since it meets harsh conditions such as high speed, a heavy load or an external heat transmission and it cools the lead screw nut. The drop lubrication is appropriate for low to medium speed and a light to medium load. Select a lubricant according to the conditions as indicated in Table2.

Table2 Selection of a Lubricant

Condition	Types of Lubricants
Low speed, high load, high temperature	High-viscosity sliding surface oil or turbine oil
High speed, light load, low temperature	Low-viscosity sliding surface oil or turbine oil

## [Grease Lubrication]

In the low-speed feed, which occurs less frequently, the user can lubricate the slide system by manually applying grease to the shaft on a regular basis or using the greasing hole on the lead screw nut. We recommend using lithium-soap group grease No. 2.

Model Number Coding

Model number configurations differ depending on the model features. Refer to the corresponding sample model number configuration.

[Lead Screw Nut]

● Models DCM, DC and CS

- Lead screw nut only

**DC20**

Model No. of lead screw nut

- Screw shaft

**CS20 T +1500L**

How the screw shaft is processed (T: rolled shaft)      Overall screw shaft length (in mm)

Model number of screw shaft

- Combination of lead screw nut and screw shaft

**2 DC20 +1500L T**

Number of lead screw nuts used on the same shaft

Model No. of lead screw nut

Overall screw shaft length (in mm)

How the screw shaft is processed (T: rolled shaft)





# Lead Screw Nut

THK General Catalog

## B Support Book

<b>Features</b> .....	B16-2
Features of the Lead Screw Nut.....	B16-2
• Structure and Features .....	B16-2
• Features of the Special Rolled Shafts..	B16-3
• High Strength Zinc Alloy.....	B16-3
<b>Point of Selection</b> .....	B16-5
Selecting a Lead Screw Nut.....	B16-5
• Example of selection calculation .....	B16-7
Efficiency and Thrust.....	B16-8
• Example of thrust force calculation .....	B16-8
<b>Mounting Procedure and Maintenance</b> ..	B16-9
Installation .....	B16-9
Lubrication .....	B16-10
<b>Model No.</b> .....	B16-11
• Model Number Coding.....	B16-11

## A Product Descriptions (Separate)

<b>Features</b> .....	A16-2
Features of the Lead Screw Nut.....	A16-2
• Structure and Features .....	A16-2
• Features of the Special Rolled Shafts..	A16-3
• High Strength Zinc Alloy.....	A16-3
<b>Point of Selection</b> .....	A16-5
Selecting a Lead Screw Nut.....	A16-5
Efficiency and Thrust.....	A16-8
Accuracy Standards .....	A16-9
<b>Dimensional Drawing, Dimensional Table</b>	
Model DCM.....	A16-10
Model DC.....	A16-12
<b>Point of Design</b> .....	A16-14
Fit.....	A16-14
Installation .....	A16-14
Lubrication .....	A16-16
<b>Model No.</b> .....	A16-17
• Model Number Coding.....	A16-17

## Features of the Lead Screw Nut

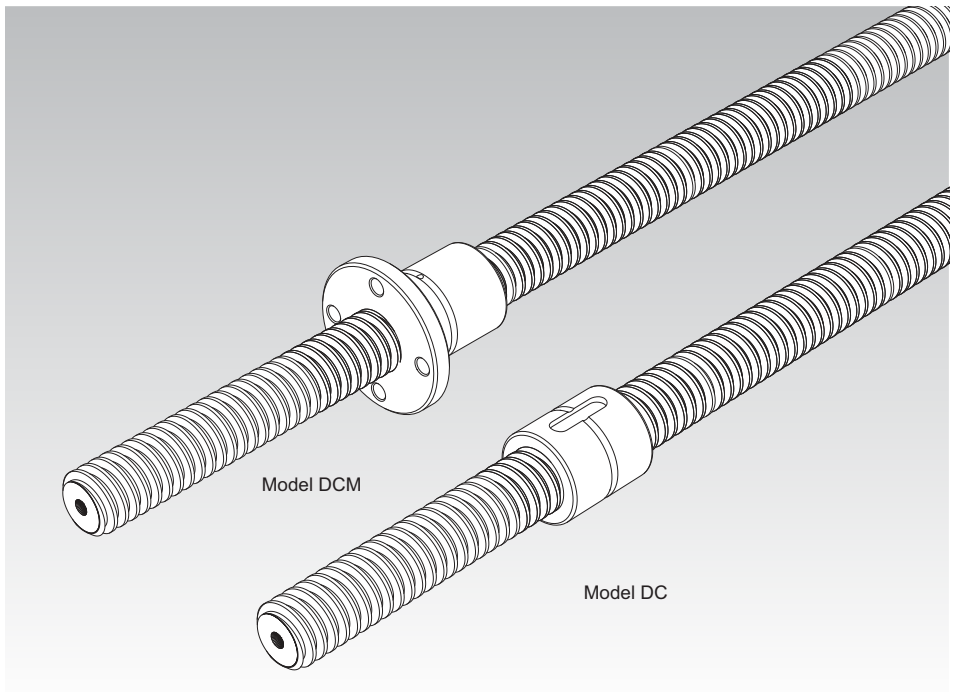

---

### Structure and Features

---

The lead Screw Nut models DCM and DC are manufactured to meet the standards for the 30° trapezoidal threads. They use a special alloy (see [B 16-3](#)) for the nuts and have a precision male thread, formed through die casting, as the core. As a result, these bearings achieve less unevenness in accuracy and higher accuracy and wear resistance than the machined lead screw nuts. For the screw shafts to be used with this product, the rolled shafts are available as the standard.

In addition, the cut screw shafts and the ground screw shafts are also available according to the application. Contact THK for details.

## Features of the Special Rolled Shafts

The dedicated rolled shafts with the standardized lengths are available for the Lead Screw Nut.

### [Increased Wear Resistance]

The shaft teeth are formed by cold gear rolling, and the surface of the tooth surface is hardened to over 250 HV and are mirror-finished. As a result, the shafts are highly wear resistant and achieve significantly smooth motion when used in combination with lead screw nuts.

### [Improved Mechanical Properties]

Inside the teeth of the rolled shaft, a fiber flow occurs along the contour of the tooth surface of the shaft, making the structure around the teeth roots dense. As a result, the fatigue strength is increased.

### [Additional Machining of the Shaft End Support]

Since each shaft is rolled, additional machining of the support bearing of the shaft end can easily be performed by lathing or milling.

## High Strength Zinc Alloy

The high strength zinc alloy used in the lead screw nuts is a material that is highly resistant to seizure and the wear and has a high load carrying capacity. Its composition, the mechanical properties, the physical properties and the wear resistance are given below.

### [Composition]

Table1 Composition of the High Strength Zinc Alloy  
Unit: %

Item	Description
Al	3 to 4
Cu	3 to 4
Mg	0.03 to 0.06
Be	0.02 to 0.06
Ti	0.04 to 0.12
Zn	Remaining portion

## [Mechanical Properties]

Table2

Item	Description
Tensile strength	275 to 314 N/mm <sup>2</sup>
Tensile yield strength (0.2%)	216 to 245 N/mm <sup>2</sup>
Compressive strength	539 to 686 N/mm <sup>2</sup>
Compressive yield strength (0.2%)	294 to 343 N/mm <sup>2</sup>
Fatigue strength	132 N/mm <sup>2</sup> × 10 <sup>7</sup> (Schenk bending test)
Charpy impact	0.098 to 0.49 N-m/mm <sup>2</sup>
Elongation	1 to 5 %
Hardness	120 to 145 HV

## [Physical Properties]

Table3

Item	Description
Specific gravity	6.8
Specific heat	460 J/ (kg·K)
Melting point	390 °C
Thermal expansion coefficient	24 × 10 <sup>-6</sup>

## [Wear Resistance]

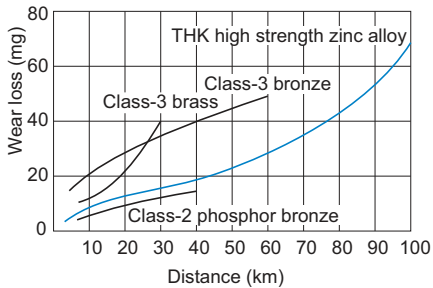

Fig. 1 Wear Resistance of the High Strength Zinc Alloy

Table4 [Test conditions: Amsler wear-tester]

Item	Description
Test piece rotational speed	185 min <sup>-1</sup>
Load	392 N
Lubricant	Dynamo oil

## Selecting a Lead Screw Nut

### [Dynamic Permissible Torque T and Dynamic Permissible Thrust F]

The dynamic permissible torque (T) and the dynamic permissible thrust (F) are the torque and the thrust at which the contact surface pressure on the tooth surface of the bearing is 9.8 N/mm<sup>2</sup>. These values are used as a measuring stick for the strength of the lead screw nut.

### [pV Value]

With a sliding bearing, a pV value, which is the product of the contact surface pressure (p) and the sliding speed (V), is used as a measuring stick to judge whether the assumed model can be used. Use the corresponding pV value indicated in Fig.1 as a guide for selecting a lead screw nut. The pV value varies also according to the lubrication conditions.

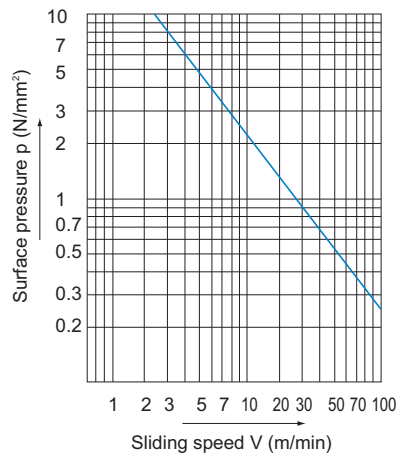

Fig.1 pV Value

### ● f<sub>s</sub>: Safety Factor

To calculate a load applied to the lead screw nut, it is necessary to accurately obtain the effect of the inertia that changes with the weight and dynamic speed of an object. In general, with the reciprocating or the rotating machines, it is not easy to accurately obtain all the factors such as the effect of the start and stop, which are always repeated. Therefore, if the actual load cannot be obtained, it is necessary to select a bearing while taking into account the empirically obtained safety factors (f<sub>s</sub>) shown in Table1.

Table1 Safety Factor (f<sub>s</sub>)

Type of load	Lower limit of f <sub>s</sub>
For a static load less frequently used	1 to 2
For an ordinary single-directional load	2 to 3
For a load accompanied by vibrations/impact	4 or greater

● **f<sub>r</sub>: Temperature Factor**

If the temperature of the lead screw nut exceeds the normal temperature range, the seizure resistance of the nut and the strength of the material will decrease. Therefore, it is necessary to multiply the dynamic permissible torque (T) and the dynamic permissible thrust (F) by the corresponding temperature factor indicated in Fig.2. Accordingly, when selecting a lead screw nut, the following equations need to be met in terms of its strength.

Static permissible thrust(F)

$$f_s \leq \frac{f_r \cdot F}{P_F}$$

- f<sub>s</sub> : Safety factor (see Table1 on [B16-5](#))
- f<sub>r</sub> : Temperature factor (see Fig.2)
- F : Dynamic permissible thrust (N)
- P<sub>F</sub> : Axial load (N)

● **Hardness of the Surface and the Wear Resistance**

The hardness of the shaft significantly affects the wear resistance of the lead screw nut. If the hardness is equal to or less than 250 HV, the abrasion loss increases as indicated in Fig.3. The roughness of the surface should preferably be 0.80a or less.

A special rolled shaft achieves the surface hardness of 250 HV or greater, through hardening as a result of rolling, and surface roughness of 0.20a or less. Therefore, the dedicated rolled shaft is highly wear resistant.

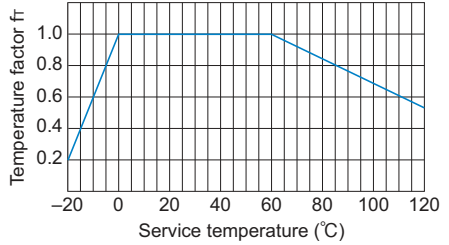

Fig.2 Temperature Factor

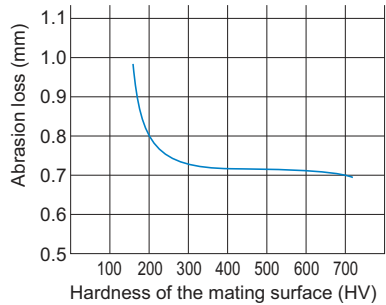

Fig.3 Hardness of the Surface and Wear Resistance

**[Calculating the Contact Surface Pressure p]**

The value of “p” is obtained as followed.

$$p = \frac{P_F}{F} \times 9.8$$

- p : Contact surface pressure on the tooth from an axial load ( $P_F$  N) (N/mm<sup>2</sup>)  
 F : Dynamic permissible thrust (N)  
 $P_F$  : Axial load (N)

**[Calculating the Sliding Speed V on the Teeth]**

The value of “V” is obtained as followed.

$$V = \frac{\pi \cdot D_o \cdot n}{\cos \alpha \times 10^3}$$

- V : Sliding speed (m/min)  
 $D_o$  : Effective diameter (see specification table) (mm)  
 n : Revolutions per minute (min<sup>-1</sup>)

$$n = \frac{S}{R \times 10^{-3}}$$

- S : Feeding speed (m/min)  
 R : Lead (mm)  
 $\alpha$  : Lead angle (see specification table) (°)

**Example of selection calculation**

Assuming that Lead Screw Nut model DCM is used, select a lead screw nut that travels at feed speed  $S = 3$  m/min while receiving an axial load  $P_F = 1,080$  N, which is applied in one direction. First, tentatively select model DCM32 (dynamic permissible thrust  $F = 21,100$  N). Obtain the contact surface pressure (p).

$$p = \frac{P_F}{F} \times 9.8 = \frac{1080}{21100} \times 9.8 \doteq 0.50 \text{ N/mm}^2$$

Obtain the sliding speed (V).

The rotation speed per minute (n) of the screw shaft needed to move it at feed speed  $S = 3$  m/min is calculated as follows.

$$n = \frac{S}{R \times 10^{-3}} = \frac{3}{6 \times 10^{-3}} = 500 \text{ min}^{-1}$$

$$V = \frac{\pi \cdot D_o \cdot 500}{\cos \alpha \times 10^3} = \frac{\pi \times 29 \times 500}{\cos 3^\circ 46' \times 10^3} \doteq 45.6 \text{ m/min}$$

From the diagram of pV values (see Fig.1 on **B16-5**), it is judged that there will be no abnormal wear if the sliding speed (V) is 47 m/min or below against the “p” value of 0.50 N/mm<sup>2</sup>. Second, obtain the safety factor ( $f_s$ ) against the dynamic permissible thrust (F). Given the conditions: temperature factor  $f_T = 1$  and applied load  $P_F = 1,080$  N, the safety factor is calculated as follows.

$$f_s \leq \frac{f_T \cdot F}{P_F} = \frac{1 \times 21100}{1080} = 19.5$$

Since the required strength will be met if “ $f_s$ ” is at least 2 because of the type of load, it is appropriate to select model DCM32.

# Efficiency and Thrust

The efficiency ( $\eta$ ) at which the screw transfers a torque into thrust is obtained from the following equation.

$$\eta = \frac{1 - \mu \tan \alpha}{1 + \mu / \tan \alpha}$$

$\eta$  : Efficiency

$\alpha$  : Lead angle

$\mu$  : Frictional resistance

Fig.4 shows the result of the above equation.

The thrust generated when a torque is applied is obtained from the following equation.

$$F_a = \frac{2 \cdot \pi \cdot \eta \cdot T}{R \times 10^{-3}}$$

$F_a$  : Thrust generated (N)

$T$  : Torque (input) (N-m)

$R$  : Lead (mm)

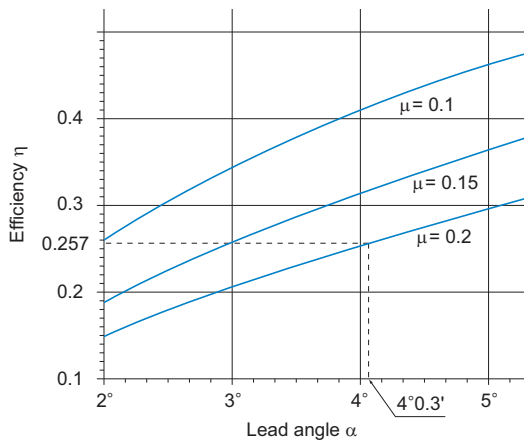

Fig.4 Efficiency

## Example of thrust force calculation

Assuming that Lead Screw Nut model DCM20 is used and the input torque  $T = 19.6$  N-m, obtain the thrust to be generated.

Calculate the efficiency ( $\eta$ ) when  $\mu = 0.2$ .

The lead angle ( $\alpha$ ) of model DCM20:  $4^{\circ}03'$

From the diagram in Fig.4, the efficiency ( $\eta$ ) when the friction coefficient  $\mu = 0.2$  is obtained as  $\eta = 0.257$ .

Obtain the thrust generated.

$$F_a = \frac{2 \cdot \pi \cdot \eta \cdot T}{R \times 10^{-3}} = \frac{2 \times \pi \times 0.257 \times 19.6}{4 \times 10^{-3}} \doteq 7700 \text{ N}$$

# Installation

## [About Chamfer of the Housing's Mouth]

To increase the strength of the root of the flange of the lead screw nut, the corner is machined to have an R shape. Therefore, it is necessary to chamfer the inner edge of the housing's mouth.

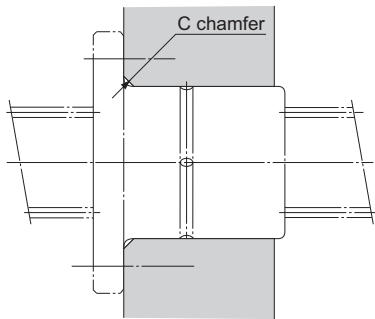

Fig.1

## [Recommended Mounting Orientation]

When vertically conveying a heavy object using the screw shaft, it is safe to mount the screw as shown in Fig.2 where supports are provided on the mounting holes to prevent the moving object from falling even if the lead screw nut is broken due to an overload or an impact.

Table1 Chamfer of the Housing's Mouth

Unit: mm

Model No.	Chamfer of the mouth C (Min.)
DCM	
12	2
14	
16	
18	
20	2.5
22	
25	
28	
32	3
36	
40	
45	
50	

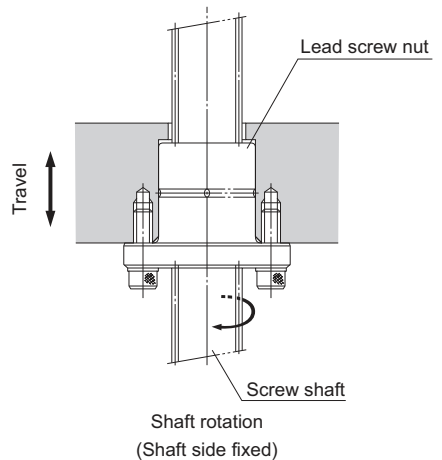

Fig.2 Recommended Mounting Orientation

### [Example of Installation]

Fig.3 shows examples of mounting the lead screw nuts. When mounting a lead screw nut, secure sufficient tightening strength in the axial direction. For the housing inner-diameter tolerance, see the section concerning fitting on **A16-14**.

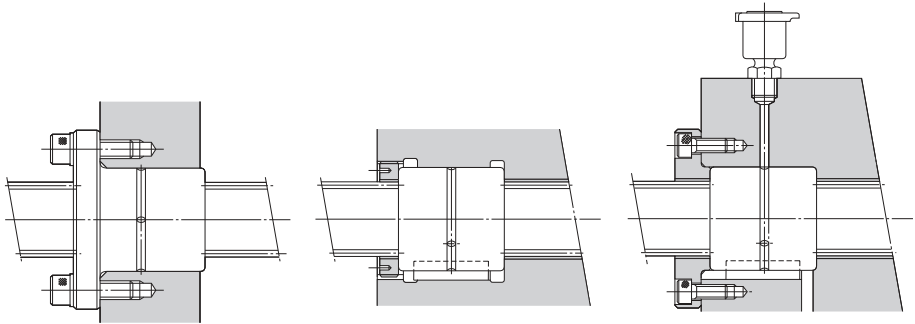

Fig.3 Examples of Installing the Lead Screw Nut

## Lubrication

Since the Screw Nut is delivered without a lubricant/grease, it is necessary to replenish an appropriate amount of lubricant/grease after installing the bearing.

Select a lubrication method according to the service conditions.

### [Oil Lubrication]

For lubrication of the lead screw nut, an oil lubrication is recommended. Specifically, an oil-bath lubrication or drop the lubrication is particularly effective. An oil-bath lubrication is the most appropriate method since it meets harsh conditions such as high speed, a heavy load or an external heat transmission and it cools the lead screw nut. The drop lubrication is appropriate for low to medium speed and a light to medium load. Select a lubricant according to the conditions as indicated in Table2.

Table2 Selection of a Lubricant

Condition	Types of Lubricants
Low speed, high load, high temperature	High-viscosity sliding surface oil or turbine oil
High speed, light load, low temperature	Low-viscosity sliding surface oil or turbine oil

### [Grease Lubrication]

In the low-speed feed, which occurs less frequently, the user can lubricate the slide system by manually applying grease to the shaft on a regular basis or using the greasing hole on the lead screw nut. We recommend using lithium-soap group grease No. 2.

## Model Number Coding

Model number configurations differ depending on the model features. Refer to the corresponding sample model number configuration.

### [Lead Screw Nut]

#### ● Models DCM, DC and CS

- Lead screw nut only

**DC20**

Model No. of lead screw nut

- Screw shaft

**CS20 T +1500L**

How the screw shaft is processed (T: rolled shaft)      Overall screw shaft length (in mm)

Model number of screw shaft

- Combination of lead screw nut and screw shaft

**2 DC20 +1500L T**

Number of lead screw nuts used on the same shaft

Model No. of lead screw nut

Overall screw shaft length (in mm)

How the screw shaft is processed (T: rolled shaft)

